

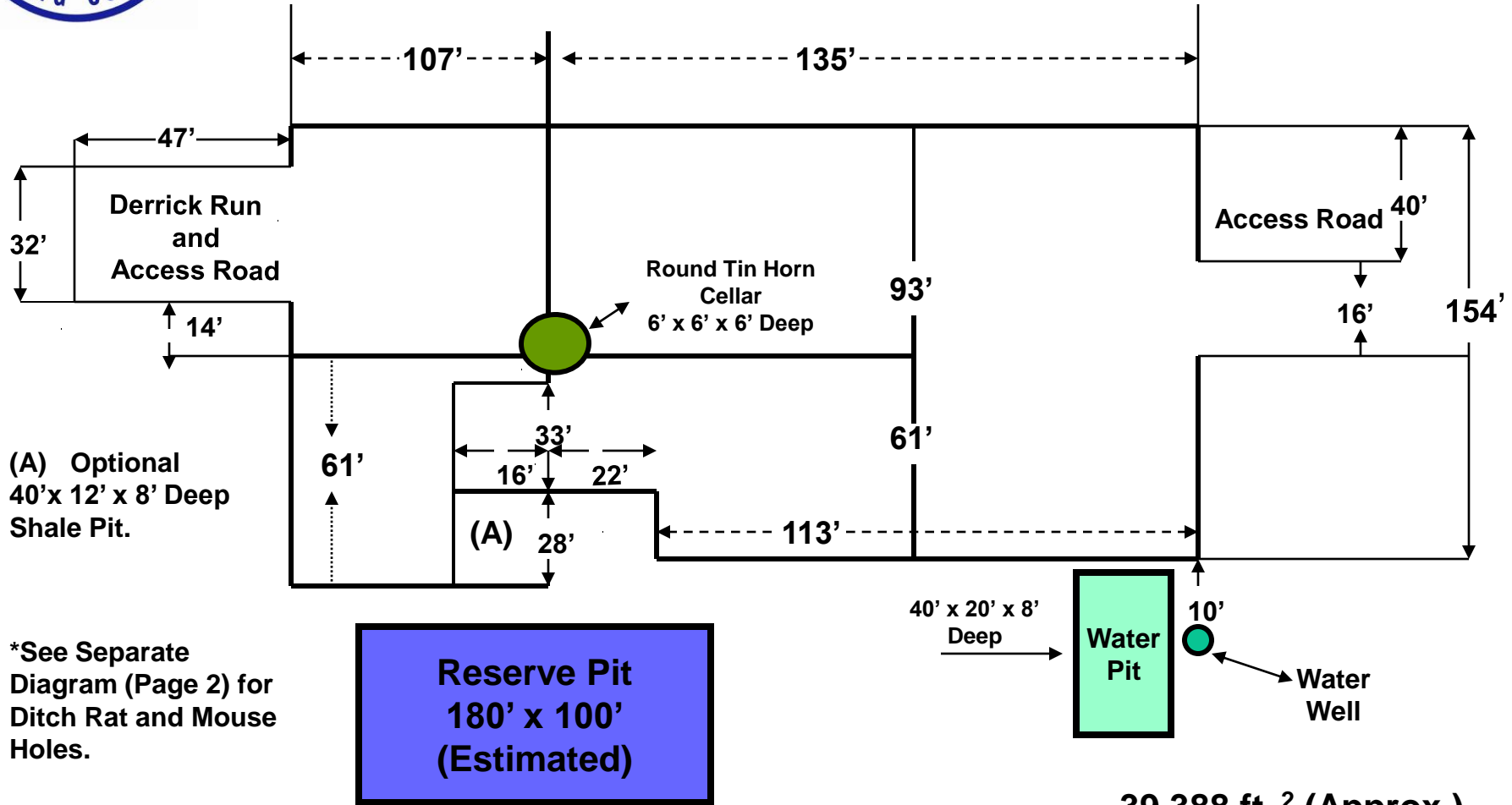

**BIG "6" DRILLING COMPANY  
LOCATION SPECIFICATIONS  
RIG #6**



(A) Optional  
40'x 12' x 8' Deep  
Shale Pit.

\*See Separate  
Diagram (Page 2) for  
Ditch Rat and Mouse  
Holes.

**Reserve Pit  
180' x 100'  
(Estimated)**

**Water Pit**  
40' x 20' x 8'  
Deep

Water Well

**39,388 ft. <sup>2</sup> (Approx.)**

**NOTE: Leave 3 Bundles of Loose Boards  
On Location to Level Rig and Strip Pipe  
Racks.**

**NOTE: Not Drawn to Scale.**